

Parts List and Wiring Diagrams

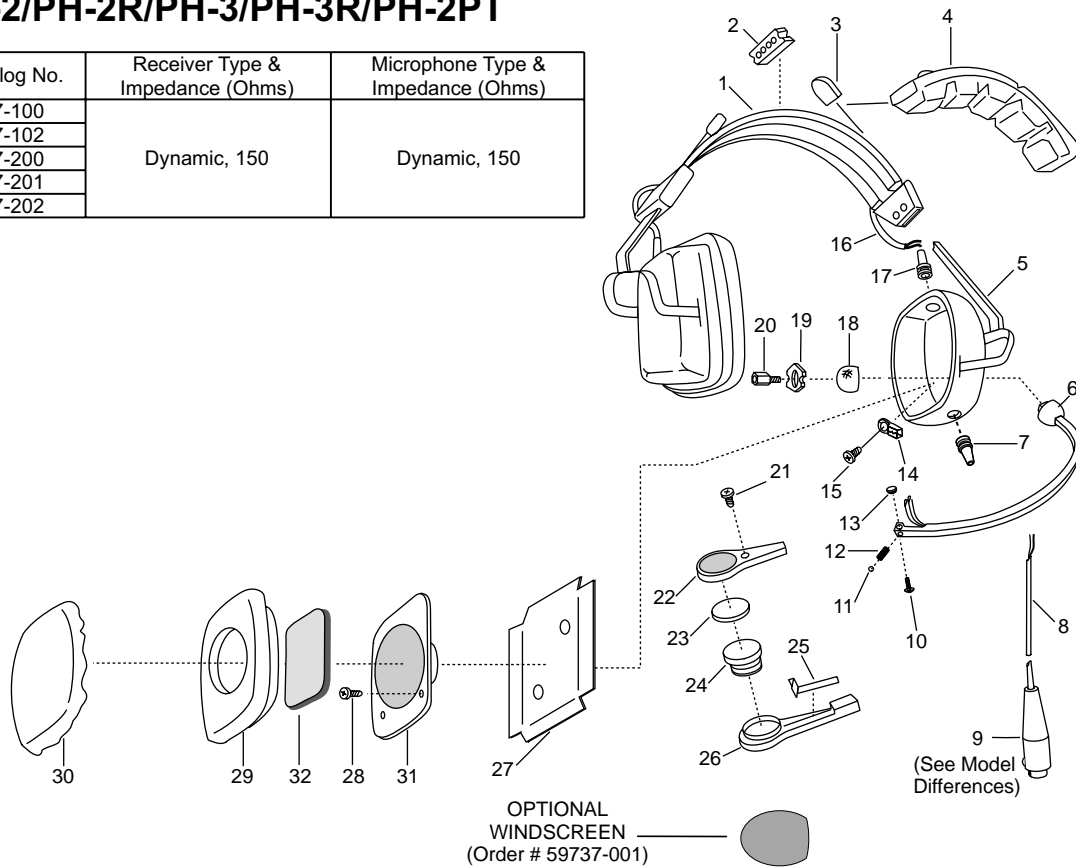

Models PH-2/PH-2R/PH-3/PH-3R/PH-2PT

Model No.	Catalog No.	Receiver Type & Impedance (Ohms)	Microphone Type & Impedance (Ohms)
PH-2	64437-100	Dynamic, 150	Dynamic, 150
PH-2R	64437-102		
PH-3	64437-200		
PH-3R	64437-201		
PH-2PT	64437-202		



ITEM NO.	DESCRIPTION	MODEL/QTY					PART NO.
		PH-2	PH-2R	PH-3	PH-3R	PH-2PT	
1	Headband Assy	1	1	1	1	1	61162-046
2	Headband Spacer	1	1	1	1	1	63709-001
3	Slider Tip	2	2	2	2	2	61166-005
4	Headpad	1	1	1	1	1	63801-001
5	Earcup-Yoke-Slider Assy, Boom Side ¹	1	1	1	1	1	70398-009
	Earcup-Yoke-Slider Assy, Boomless Side ¹	1	1	1	1	1	70398-010
6	Boom Assembly	1	1	1	1	1	70398-001
7	Strain Relief	1	1	1	1	1	63465-006
8	Cord Unit	1	1	1	1	1	63988-065
9	Connector, PH-2, XLR-4F	1				NA	35320-004
	Connector, PH-2R, XLR-4M		1			NA	35398-004
	Connector, PH-3, XLR-5F			1		NA	35320-005
	Connector, PH-3R, XLR-5M				1	NA	35398-005
10	Drive Screw	1	1	1	1	1	35135-000
11	Steel Ball	1	1	1	1	1	50772-002
12	Spring	1	1	1	1	1	54336-000
13	Boom Stop	1	1	1	1	1	63189-000
14	Terminal	1	1	1	1	1	54462-001
15	Screw, No. 6-20 x 1/4	1	1	1	1	1	51856-008
16	Cord Assembly, Overhead	1	1	1	1	1	60051-189

ITEM NO.	DESCRIPTION	MODEL/QTY					PART NO.
		PH-2	PH-2R	PH-3	PH-3R	PH-2PT	
17	Strain Relief	2	2	2	2	2	63488-000
18	Ball Half	1	1	1	1	1	63451-003
19	Ball Joint Spring	1	1	1	1	1	63453-000
20	Hex Spacer	2	2	2	2	2	57907-000
21	Screw, No. 6-20 x 1/4	1	1	1	1	1	51856-002
22	Mic Housing Cover	1	1	1	1	1	63460-005
23	Foam	1	1	1	1	1	63124-018
24	Mic Element Assy	1	1	1	1	1	61585-037
25	Contact Tension Spring	1	1	1	1	1	63455-000
26	Mic Housing	1	1	1	1	1	63459-005
27	Foam Liner	2	2	2	2	2	63763-000
28	Screw, No. 4-40 x 1/4	4	4	4	4	4	51845-038
29	Ear Cushion	2	2	2	2	2	63444-001
30	Ear Cushion Cover	2	2	2	2	2	35772-000
31	Rcvr Element-Earplate Assy	2	2	2	2	2	70398-036
32	Foam	2	2	2	2	2	70608-000

¹One (1) slider tip (item no. 3) is supplied with this part. Slider tip should be glued to slider using an epoxy adhesive.

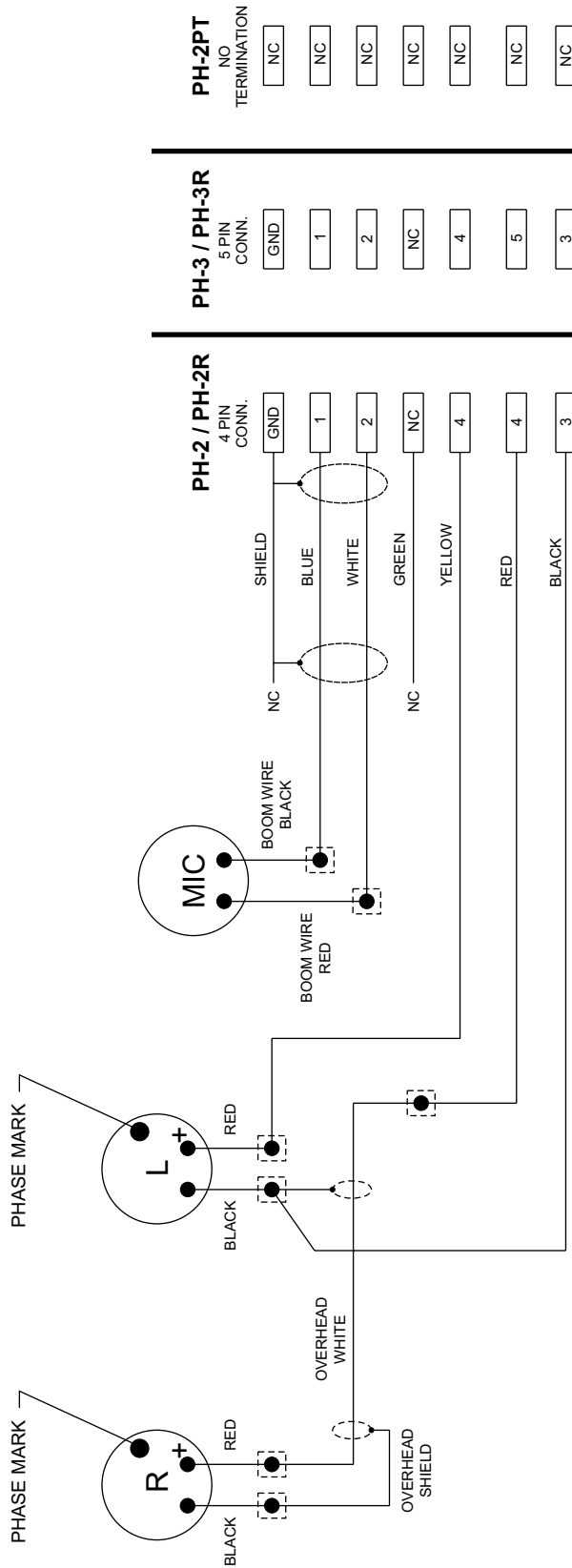

WIRING DIAGRAM

